

FIG. 1

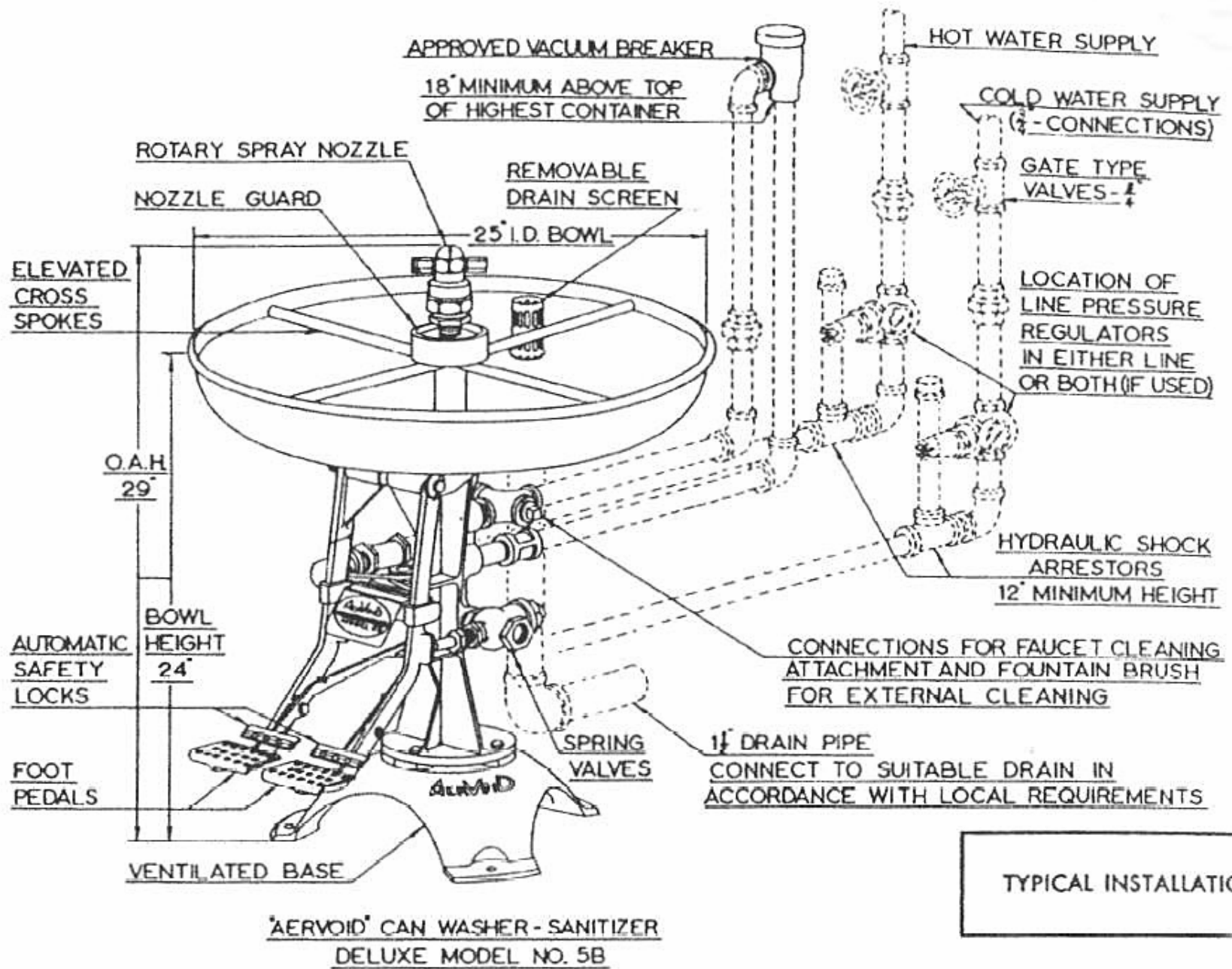
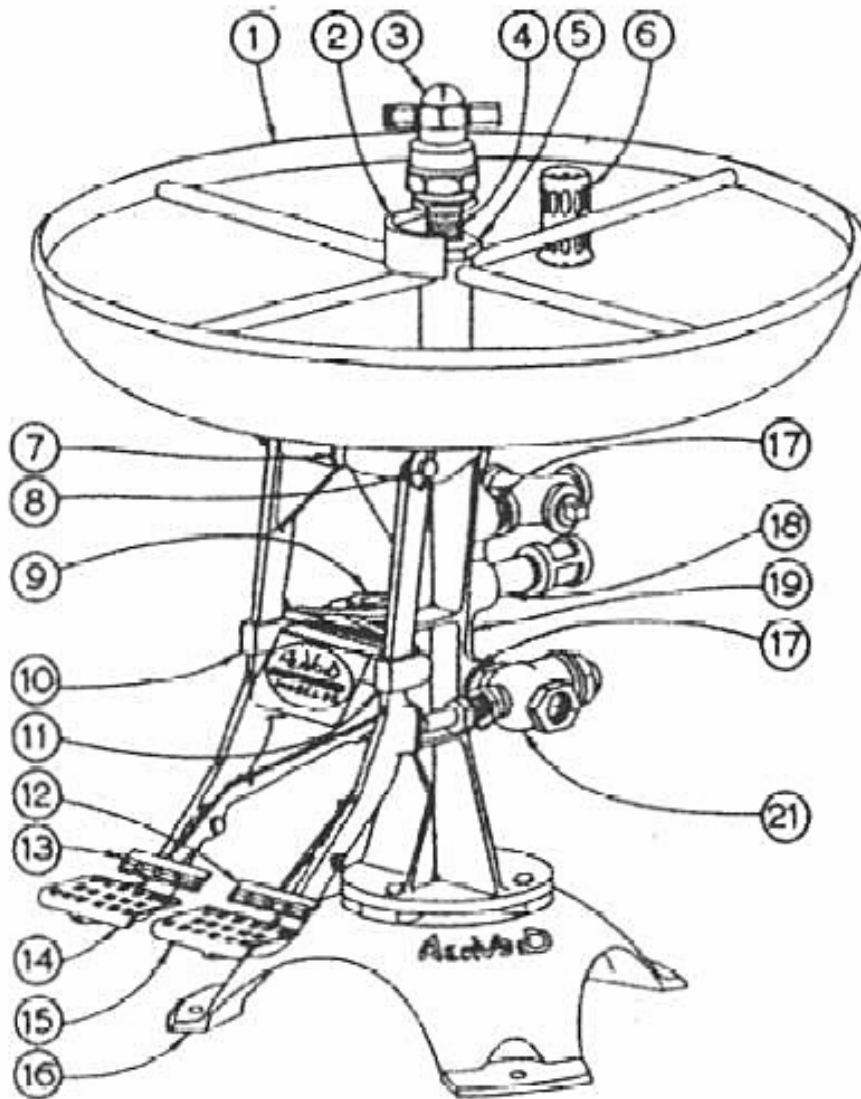

FIG. 2



REPLACEABLE PARTS		
DET. NO.	DESCRIPTION	PART NO.
1	BOWL ASSY.	SA-ST-1-5B
2	NOZZLE GUARD	ST-92-5A
3	ROTARY NOZZLE ASSY.	SA-ST-34-5A
4	RISER TUBE	ST-59-5B
5	SPOKE HUB LOCKNUT	ST-174-5B
6	DRAIN SCREEN	ST-155-4A
7	PEDAL SPACER	OBSOLETE
8	PEDAL SHAFT	ST-147-5B
9	PEDAL RETURN SPRING	ST-121-5A
10	PEDAL GUIDE BRACKET	ST-79-5B
11	PEDAL GUIDE BRACKET	ST-79-5B
12	PEDAL LOCK - RIGHT	ST-95-5B F
13	PEDAL LOCK - LEFT	ST-96-5B F
14	PEDAL - LEFT	ST-148-5B F
15	PEDAL - RIGHT	ST-62-5B F
16	BASE	ST-2-5B
17	NIPPLES (3) - STAINLESS STL.	ST-116-5
18	NIPPLE - STAINLESS STL.	ST-175-5B
19	PEDESTAL	ST-3-5B F
21	SPRING VALVES (2)	ST-12-5B

OPTIONAL PARTS	
DESCRIPTION	PART NO.
FOUNTAIN BRUSH	FB-1
CHECK VALVE	ST-143-4A
VACUUM BREAKER	ST-156-4A

FIG. 3

**"AERVOID" CAN WASHER-SANITIZER
DELUXE MODEL NO. 5B
DIMENSIONS FOR INSTALLATION**

